

Commercial Top-Load Dryer - Non-Coin

Whirlpool
COMMERCIAL
LAUNDRY



CEM2795JQ / CGM2795JQ

Why Buy: Choose a commercial-built product that withstands heavy traffic, regular use, and performs continuously.

Commercial-Grade Cabinet



The robust cabinet is made from heavy-gauge galvanized steel to provide long-lasting protection, with an easy-to-remove front panel for streamlined service.

Full-Wrap Console



The metal console wraps completely around the back of the machine, making it easy to clean, and offering optimal protection against unexpected liquid spills or vapor.

Reversible, 180° Wide-Opening, Side-Swing Door

180°

The side-swing door gives unhindered access for loading and unloading, while the 180° opening gives optimal flexibility in any space. Made from heavy-gauge, galvanized steel, it's designed for regular use.

Whirlpool
COMMERCIAL
LAUNDRY

**2-YEAR LIMITED
PARTS ONLY
WARRANTY / 90-DAY LABOR**

For 90 days from the date of the original purchase, when this commercial appliance is installed, maintained, and operated according to instructions attached to or furnished with the product, Whirlpool Corporation (hereafter "Whirlpool") will pay for factory-specified replacement parts and repair labor to correct defects in materials or workmanship that existed when this commercial appliance was purchased. For the first two years from the date of purchase, when this major appliance is installed, maintained, and operated according to the instructions attached to or furnished with the product, Whirlpool will pay for factory-specified replacement parts to correct defects in materials or workmanship that existed when this commercial appliance was purchased.

See whirlpoolcommerciallaundry.com for warranty details.

Commercial Top-Load Dryer - Non-Coin



Electric Dryer CEM2795JQ & Gas Dryer CGM2795JQ At A Glance:

- 7.4 cu. ft.
- 3 cycles, 3 temperatures
- Non-coin
- Reversible, 180° wide-opening, side-swing door
- Four-roller suspension
- Galvanized, heavy-gauge cabinet
- 1/3-HP motor
- Removable, door-mounted lint screen
- Card reader compatible*
- 2-Year Limited Parts Warranty/90-Day Labor**

MODEL	Non-Coin	CEM2795JQ	CGM2795JQ
Fuel Type		U.S. Electric	U.S. Gas
SPECIFICATIONS			
CAPACITY			
Cylinder Volume — cu. ft. (liters)		7.4 (210)	7.4 (210)
Cylinder Diameter — in. (mm)		26.26 (667)	26.26 (667)
Cylinder Depth — in. (mm)		23.2 (590)	23.2 (590)
ELECTRICAL REQUIREMENTS			
Voltage		240V	120V
Electrical Requirements / Frequency		60Hz	60Hz
Breaker / Fuse — amps [†]		30	15
AIRFLOW (CFM)		178	183
DRYER EXHAUST DUCT DIAMETER — IN. (MM)**		4 (101.6)	4 (101.6)
ELECTRIC HEATING ELEMENT (WATTS)		5,600	5,600
GAS RATING — BTU/HR. (KCAL/HR.)		22,000 (5,544)	22,000 (5,544)
GAS INLET SIZE		N/A	3/8 N.P.T
MOTOR SIZE — HP (KW)		1/3 (.25)	1/3 (.25)
DIMENSIONS			
MACHINE DIMENSIONS			
Width (with door closed) — in. (mm)		27 (686)	27 (686)
Depth — in. (mm)		29.25 (743)	29.25 (743)
Height — in. (mm)		41 (1,042)	41 (1,042)
Door Opening — in. (mm)		20.25 (514)	20.25 (514)
CRATED DIMENSIONS			
Crated Width — in. (mm)		28.8 (731)	28.8 (731)
Crated Depth — in. (mm)		30.8 (782)	30.8 (782)
Crated Height — in. (mm)		44.65 (1,134)	44.65 (1,134)
APPROXIMATE WEIGHT			
Uncrated — lbs. (kg)		115 (52.2)	120 (54.4)
Crated — lbs. (kg)		125 (56.7)	139 (59)

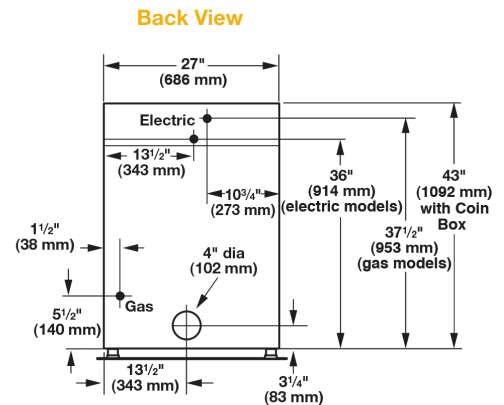
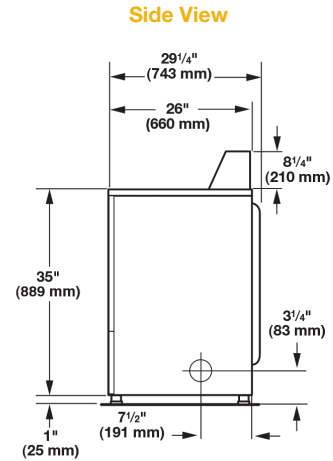

Dimensions are for planning purposes only. See specific instructions for proper installation. Because of continuous product improvement, Whirlpool reserves the right to change specifications without notice.

*Card readers are not supplied or sold by Whirlpool Corporation and must be purchased separately.

**Visit whirlpoolcommerciallaundry.com for complete warranty details.

†It is recommended that a separate circuit serving for this dryer be provided.

**Use 4" (100mm) diameter rigid aluminum or galvanized steel duct. Never use plastic, non-metal, or combustible duct.

