

MVW18MN

MAYTAG® COMMERCIAL
ENERGY ADVANTAGE™
TOP-LOAD WASHER



LEGENDARY MAYTAG DEPENDABILITY

Maximizing your equipment investment for over a half-century.

ENERGY-SAVING SOLUTIONS

Maytag built the first appliance ever to receive the ENERGY STAR® label. Today, we offer energy-saving laundry solutions for all commercial laundry needs—from highly efficient ENERGY STAR®-qualified washers to the most energy-efficient dryers ever from Maytag—to help you save money and build profits.

FOR YOUR CUSTOMERS:

- Proven Cleaning Performance
- Extra-Large Lid and Tub Opening
- User-Friendly Controls Allow for Customized Cleaning

FOR YOUR OPERATION:

- Our Most Energy-Efficient Top-Load Washer
- Sensor Fill Water Levels Reduce Water Usage
- Maytag Connect 360™ Wireless Audit System—Option
- High-Speed Spin of 144 G-Force Reduces Dry Time

BUILT-TO-LAST™ FEATURES:

- Premium Porcelain-Enamel Top
- Smooth Balance Suspension System
- Front Access for Easier-Self Service
- 5-Year Limited Warranty—All Parts Covered

LAUNDRY SOLUTIONS
YOU CAN *DEPEND ON.*

visit maytagcommerciallaundry.com
or call 800-662-3587



OUR COMMITMENT TO DEPENDABLE QUALITY

At Maytag, we believe durable goods should remain just that. That's why every Maytag® product is constructed of the highest-quality materials and with the utmost in precision craftsmanship. It's also why we stand behind our equipment with solid service and support from our professional Maytag laundry suppliers. Simply put, when you choose Maytag® products, you ensure your peace of mind.



MVW18MN MAYTAG® COMMERCIAL ENERGY ADVANTAGE™ TOP-LOAD WASHER

Maytag® Commercial Energy Advantage™ Top-Load Washer

MECHANICAL NON-COIN

WASHER SPECIFICATIONS	
MODEL	MVW18MN
MOTOR	
Single-phase, reversible, thermoprotected, high torque	✓
HP (kw)	.33 (.25)
APPROXIMATE WATER USAGE—GALLONS (LITERS)	
Average hot water usage, hot water cycle	6.1 (22.9)*
Average hot water usage, warm water cycle	—
Average total water usage per cycle	19.9 (75)*
ELECTRIC RATING	
Domestic model—voltage/Hz	120/60
Export model—voltage/Hz	220–240/50
BREAKER/FUSE MINIMUM REQUIREMENTS	
Domestic model—amps	15
Export model—amps	10
CAPACITY	
Cylinder volume—cu. ft. (liters)	2.9 (82)
Cylinder diameter—in. (mm)	20.8 (528)
Cylinder depth—in. (mm)	23.8 (605)
EXTRACT SPEED	
Maximum RPM	700
Maximum G-Force	144
OPERATING PRESSURE	
Psi (bar)	20–100 (1–8)
INLET HOSE LENGTH	
Ft. (m)	6 (1.8)
DRAIN HOSE LENGTH	
Ft. (m)	4.2 (1.3)
ADJUSTABLE LEVELING LEGS	✓
APPROXIMATE WEIGHT	
Crated—lbs. (kg)	137 (63)
Uncrated—lbs. (kg)	122 (55)
DIMENSIONS	
Height—in. (mm)	40.8 (1,036)**
Width—in. (mm)	27 (686)
Depth—in. (mm)	25.9 (658)
Lid opening—in. (mm)	17 (432)
WARRANTY	5-YEAR

*Average based on DOE J1 testing with factory preset cycles.

**Height at metercase top does not include pedestal.

Dimensions are for planning purposes only. See specific instructions for proper installation. Because of continuous product improvement, Maytag reserves the right to change specifications without notice. Export model ships without coin-drop mechanism.

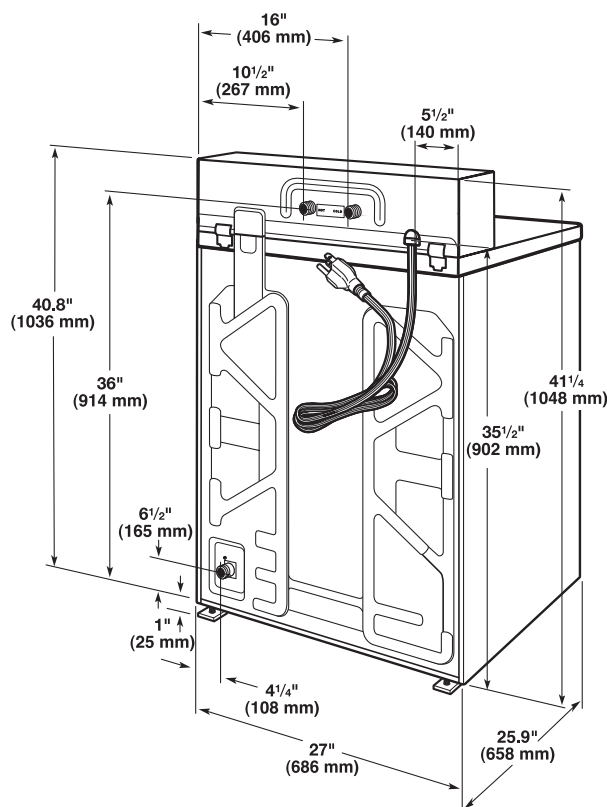

NEW YORK CITY
M.E.A.



BEAB
Approved



5-YEAR LIMITED WARRANTY ALL PARTS COVERED

For a period from the date of original purchase through the time listed above, the designated parts that fail in normal commercial use will be repaired or replaced free of charge for the part itself, with the owner paying all other costs, including labor, transportation and customs duty. Chemical damage is excluded from all warranty coverage. See complete warranty for details.