

MLE/MLG24PR

MAYTAG® COMMERCIAL SINGLE LOAD SUPER-CAPACITY STACK DRYER



LEGENDARY MAYTAG DEPENDABILITY

Maximizing your equipment investment for over a half century.



Built with optional non-metered design.

TWO POCKETS IN THE SPACE OF ONE

You can potentially double your dryer income and help eliminate waiting with two dryer pockets in the same floor space as one single-load dryer.

FOR YOUR CUSTOMERS:

- Extra-Large 7.4 cu. ft. Capacity
- Easy To Use One-Touch Cycle Selection
- High Air Flow For Better Clothes Care
- Time Remaining Display
- Optional Top Off
- Large Window For Convenience
- No Need to Carry Quarters

FOR YOUR OPERATION:

- TurboVent™ Technology—Better Performance On Long Vents
- Advanced Computer Trac® Controls Allow For Easy Programming
- Front Access For Easier Self Service
- Accu Trac® Audit System With Two-Way Data Communication
- Large-Capacity Metal Mesh Lint Filter
- Debit Card Compatibility

BUILT-TO-LAST™ FEATURES:

- Four Roller Suspension With Permanently Lubricated Bearings
- Blower Guard Reduces Service Calls
- Best Warranty in the Business

*Shown with
optional solid
door kit.*

FASTER DRYING WITH **TURBOVENT™** TECHNOLOGY

visit maytagcommerciallaundry.com



OUR COMMITMENT TO DEPENDABLE QUALITY

At Maytag, we believe durable goods should remain just that. That's why every Maytag® product is constructed of the highest-quality materials and with the utmost in precision craftsmanship. It's also why we stand behind our equipment with solid service and support from our professional Maytag laundry suppliers. Simply put, when you choose Maytag® products, you ensure your peace of mind.



MLE/MLG24PR MAYTAG® COMMERCIAL SINGLE LOAD SUPER-CAPACITY STACK DRYER

Maytag® Super-Capacity Dryer MICROPROCESSOR CARD READER-READY

DRYER SPECIFICATIONS	
MODEL	MLE/MLG24PR
MOTOR	
Single-phase, thermoprotected against overload, auto-reset	•
HP (kw)	1/2 (.25)
CAPACITY	
Cu. ft. (liters)	7.4 (209.5)
AIRFLOW — cfm (cmm)	
Gas/Electric models — per pocket	230 (6.5)/215 (6.1)
Export, Gas/Electric models — per pocket	230 (6.5)/215 (6.1)
TUMBLE SPEED	
RPM	50 ± 1.5
ELECTRICAL REQUIREMENTS	
MDE model — voltage	240V/60Hz*
MDG model — voltage	120V/60Hz
Export models — voltage	220-240V/50 Hz
BREAKER/FUSE REQUIREMENTS — amps	
Electric model — domestic (each drying chamber)	30
Electric model — export (one terminal block per stack)	40
Electric model — Canada (one terminal block per stack)	60
Gas models, all versions — (one power cord per stack)	15
HEATER ELEMENT RATING — watts	
Domestic model — per pocket	5,600
Export models — per pocket	4,600
EXHAUST DUCT DIAMETER	
In. (mm)	4 (101.6)
ELECTRONIC BURNER IGNITION	
MDG model	•
GAS RATING	
MDG models, all versions — BTU/hr. (kcal/hr.)	24,000 (6,048)
GAS INLET	
MDG model — in.	3/8 N.P.T.
AUTOMATIC PRESSURE REGULATOR	
MDG models	•
ADJUSTABLE LEVELING LEGS	•
APPROXIMATE WEIGHT	
Crated — lbs. (kg)	275 (124.7)
Uncrated — lbs. (kg)	250 (113.4)
DIMENSIONS	
Width — in. (mm)	27 (685.8)
Depth — in. (mm)	29 (736.6)
Height — in. (mm)	76.75 (1949)

See specific instructions for proper installation. Because of continuous product improvement, Maytag reserves the right to change specifications without notice.
* 208-Volt electrical element kit available

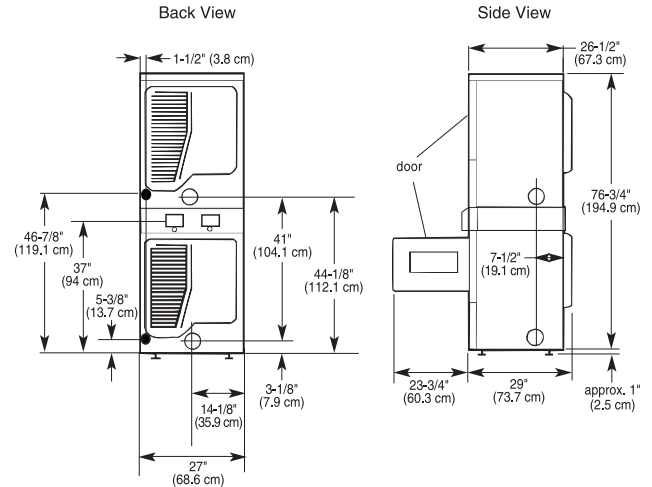

MAXIMUM EXHAUST DUCT LENGTH PER NUMBER OF TURNS

Number Of 90° Turns



Rigid Metal Vent

	Box Hood and Louvered Style	Angled Hood Style
0	135 ft. (41.2 m)	129 ft. (39.3 m)
1	125 ft. (38.1 m)	119 ft. (36.3 m)
2	115 ft. (35.1 m)	109 ft. (33.2 m)
3	106 ft. (32.3 m)	100 ft. (30.5 m)
4	98 ft. (29.9 m)	92 ft. (28.0 m)

Flexible Metal Vent

	Box Hood and Louvered Style	Angled Hood Style
0	76 ft. (23.2 m)	62 ft. (18.9 m)
1	71 ft. (21.6 m)	57 ft. (17.4 m)
2	67 ft. (20.4 m)	53 ft. (16.2 m)
3	65 ft. (19.8 m)	51 ft. (15.6 m)
4	63 ft. (19.2 m)	49 ft. (14.9 m)



NEW YORK CITY M.E.A.



BEAB Approved



5 YEARS ON ALL PARTS

For a period from the date of original purchase through the time listed above, the designated parts that fail in normal commercial use will be repaired or replaced free of charge for the part itself, with the owner paying all other costs, including labor, transportation and customs duty. Chemical damage is excluded from all warranty coverage. See complete warranty for details.