

MHN30PDB

MAYTAG® COMMERCIAL ENERGY ADVANTAGE™ HIGH-EFFICIENCY FRONT-LOAD WASHER



LEGENDARY MAYTAG DEPENDABILITY

Maximizing your equipment investment for over a half century.



- ▶ **MODIFIED ENERGY FACTOR 2.49**
- ▶ **WATER FACTOR 3.74**
- ▶ **CEE TIER III RATED**



MICROPROCESSOR CONTROLS, COIN-DROP

Maytag® Computer Trac® controls are easy to program and operate. Plus, they give owners the flexibility to set vend prices by day, time, water temperature and Super Cycle options.

A COMPLETE LINE OF ENERGY-EFFICIENT SOLUTIONS

Maytag built the first appliance ever to receive the ENERGY STAR® label. Today we offer a complete line of high-efficiency commercial laundry appliances—from industry-leading energy-efficient dryers to highly efficient ENERGY STAR®-qualified washers—to help you save money and build profits.

FOR YOUR CUSTOMERS:

- Large Capacity For Bulky Items—3.1 cu. ft.
- High-Speed Extraction Cuts Drying Time (as high as 1,000 RPMs)
- 180° Door Opening, Heavy-Duty Die-Cast Hinge For Easier Loading and Unloading
- Easy-To-Use One-Touch Cycle Selection
- Flexible Wash Options
- Quick Cycle Reduces Total Wash Time
- Automatic Detergent, Softener And Bleach Dispenser Drawer
- Large Display For Convenience
- Front Control Panel 22° Angle For Easy Viewing
- ADA-Compliant With Optional Pedestal

FOR YOUR OPERATION:

- High-Efficiency Design Meets CEE Tier III Rating
- TurboWash™ System Delivers Better Cleaning With Less Average Water Use Per Cycle
- Super Cycle Option Increases Revenue
- Self-Diagnostic Feature Cuts Service Cost And Minimizes Downtime
- Accu Trac® Audit System With Two-Way Data Communication
- Card Reader Compatible
- Advanced Computer Trac® Controls Allow For Easy Programming
- Simple Soft-Mount Design For Easy Installation
- Dual Coin-Drop Option

BUILT-TO-LAST™ FEATURES:

- Porcelain-Enamel Top With Backsplash
- Precision Endurance Drive
- Controlled Induction Motor
- High Security Vault
- 5 Year Limited Warranty—All Parts Covered

LAUNDRY SOLUTIONS
YOU CAN *DEPEND* ON.

SAVE UP TO 60% YEARLY*
ON ENERGY, WATER AND SEWER COSTS

visit maytagcommerciallaundry.com
or call 800-662-3587

*Maytag® Commercial front-load washer compared to commercial top-load washer. Individual savings may vary.



OUR COMMITMENT TO DEPENDABLE QUALITY

At Maytag, we believe durable goods should remain just that. That's why every Maytag® product is constructed of the highest-quality materials and with the utmost in precision craftsmanship. It's also why we stand behind our equipment with solid service and support from our professional Maytag laundry suppliers. Simply put, when you choose Maytag® products, you ensure your peace of mind.



MHN30PDB

MAYTAG® COMMERCIAL ENERGY ADVANTAGE™ HIGH-EFFICIENCY FRONT-LOAD WASHER

Maytag® Energy Advantage™ HE Front-Load Washer MICROPROCESSOR CONTROLS, COIN-DROP

WASHER SPECIFICATIONS	
MODEL	MHN30PDB
MOTOR	
Variable-speed, reversible, thermoprotected, high-efficiency, controlled induction	Yes
Wash—HP (kw)	.09 (.07)
Extract—HP (kw)	.54 (.40)
Average energy consumption per cycle (kWh)	.054
CAPACITY	
Cylinder volume—cu. ft. (liters)	3.1 (88)
Cylinder diameter—in. (mm)	21.6 (547)
Cylinder depth—in. (mm)	13.4 (341)
APPROXIMATE WATER USAGE—GALLONS (LITERS)	
Average hot water usage, hot water cycle	3.4 (12.8)
Average hot water usage, warm water cycle	1.6 (6.1)
Average total water usage per cycle	12.4 (47)*
ELECTRICAL RATING	
Domestic model—voltage	120V/60Hz
Export model—voltage	220–240V/50Hz
BREAKER/FUSE MIN. REQUIREMENTS	
Domestic amps	15
Export amps	10
SOUND LEVEL (export model only)	
Sound pressure level, Lpa (dBa) (Kpa: +/- 3.6 dbA)	58
DOOR OPENING	
Sq. in.	143
WASH SPEED	
RPM	40
EXTRACT SPEED	
Maximum RPM	1,000
Maximum g-force	306
WATER SUPPLY PRESSURE	
Psi (bar)	20–100 (1–8)
INLET HOSE	
Ft. (m)	4 (1.22)
DRAIN HOSE	
Ft. (m)	6 (1.83)
ADJUSTABLE LEVELING LEGS	Yes
APPROXIMATE WEIGHT	
Crated—lbs. (kg)	254 (115)
Uncrated—lbs. (kg)	245 (111)
DIMENSIONS	
Width—in. (mm)	27 (686)
Depth—in. (mm)	29.25 (743)
Height—in. (mm)	45.67 (1160)**
OPTIONAL PEDESTAL ADD:	
Height—in. (mm)	2.75 (70)

* Average based on DOE J1 testing with factory preset cycles.
 ** Height at metercase top does not include pedestal.
 Dimensions are for planning purposes only. See specific instructions for proper installation. Because of continuous product improvement, Maytag reserves the right to change specifications without notice.
 Export model ships without coin-drop mechanism.

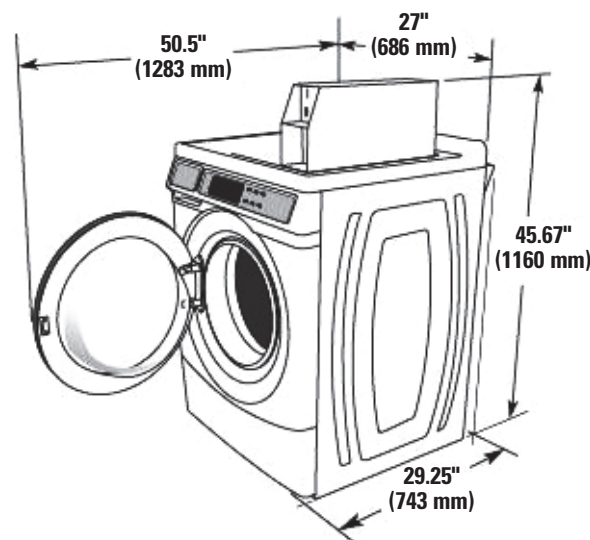

NEW YORK CITY
M.E.A.



BEAB
Approved



5 YEAR LIMITED WARRANTY— ALL PARTS COVERED

For a period from the date of original purchase through the time listed above, the designated parts that fail in normal commercial use will be repaired or replaced free of charge for the part itself, with the owner paying all other costs, including labor, transportation and customs duty. Chemical damage is excluded from all warranty coverage. See complete warranty for details.