

MDG52PN

MAYTAG® COMMERCIAL
ENERGY ADVANTAGE™
MULTI-LOAD DRYER



LEGENDARY MAYTAG DEPENDABILITY

Maximizing your equipment investment for over a half-century.

ENERGY-SAVING SOLUTIONS

Maytag built the first appliance ever to receive the ENERGY STAR® label. Today, we offer energy-saving laundry solutions for all commercial laundry needs—from highly efficient ENERGY STAR®-qualified washers to the most energy-efficient dryers ever from Maytag—to help you save money and build profits.

ADVANCED CONTROLS

Includes Maytag® Accu Trac® audit system that uses a PDA to communicate with the microprocessor controls—so you can set up, monitor and audit your equipment in seconds.

CAPACITY:

- 50-Lb. Capacity

FOR YOUR CUSTOMERS:

- Extra-Large Door Opening with Dual-Pane Door Glass
- Time Remaining Digital Display
- Self-Diagnostic Microprocessor Controls

FOR YOUR OPERATION:

- Owner-Programmable Single-Phase Reversing Cylinder
- Low BTU and Fast Dry
- Enhanced Insulation For Greater Efficiency
- Front Serviceable
- Accu Trac® Audit System With Two-Way Data Communication
- Large-Capacity Lint Drawer

BUILT-TO-LAST™ FEATURES:

- Maytag® Exclusive Waterless Fire Suppression System
- Heavy-Duty Motors
- Permanently Lubricated Bearings
- Four-Point Roller Support System
- 3-Year Limited Warranty—All Parts Covered

LAUNDRY SOLUTIONS
YOU CAN *DEPEND* ON.

visit maytagcommerciallaundry.com
or call 800-662-3587



OUR COMMITMENT TO DEPENDABLE QUALITY

At Maytag, we believe durable goods should remain just that. That's why every Maytag® product is constructed of the highest-quality materials and with the utmost in precision craftsmanship. It's also why we stand behind our equipment with solid service and support from our professional Maytag laundry suppliers. Simply put, when you choose Maytag® products, you ensure your peace of mind.

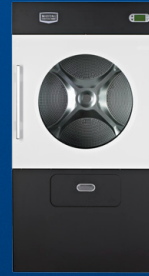

MDG52PN

MAYTAG® COMMERCIAL ENERGY ADVANTAGE™ MULTI-LOAD DRYER

Maytag® Commercial Energy Advantage™ Multi-Load Dryer

MICROPROCESSOR NON-COIN

DRYER SPECIFICATIONS	
MODEL	MDG52PN
CAPACITY	
Lbs. (kg)	50 (22.68)
Cu. ft. (cu. m)	16.02 (.453)
TUMBLER	
Diameter—in. (mm)	37 (940)
Depth—in. (mm)	25.75 (654)
MOTOR	
Single-phase, thermoprotected against overload, auto-reset	✓
HP (kw) tumbler/blower	.75 (.56) / .50 (.37)
Tumble speed—RPM	40 ± 1.5
AIRFLOW	
Cfm (cmm)	600 (17.00)
GAS RATING	
BTU/hr. (kcal/hr.)	110,000 (27,720)
GAS INLET	
M.N.P.T. in. (mm)	1 inlet, 0.50 (12.7)
VOLTAGE/BREAKER/FUSE REQUIREMENTS	
Volts (Hz)	120 (60)
Amps	25
Export models—options available	220–480V/50–60Hz/1PH or 3PH
COLOR	
White	✓
Stainless Steel	✓
APPROXIMATE WEIGHT	
Crated—lbs. (kg)	640 (290)
Uncrated—lbs. (kg)	610 (277)
DIMENSIONS	
Height—in. (mm)	70.5 (1,791)
Width—in. (mm)	38.25 (972)
Depth—in. (mm)	40.13 (1,019)
Exhaust duct diameter—in. (mm)	8 (203)*
Door opening diameter—in. (mm)	27.38 (695)

*Requires 8" (203 mm) material if venting horizontally; 10" (254 mm) if venting vertically. See specific instructions for proper installation. Because of continuous product improvement, Maytag reserves the right to change specifications without notice.

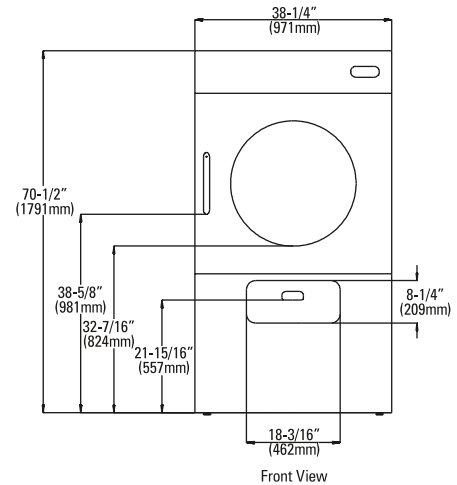

Front View

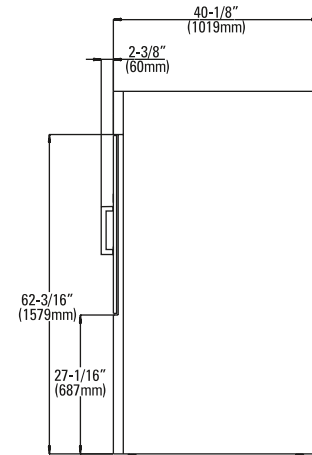

Side View

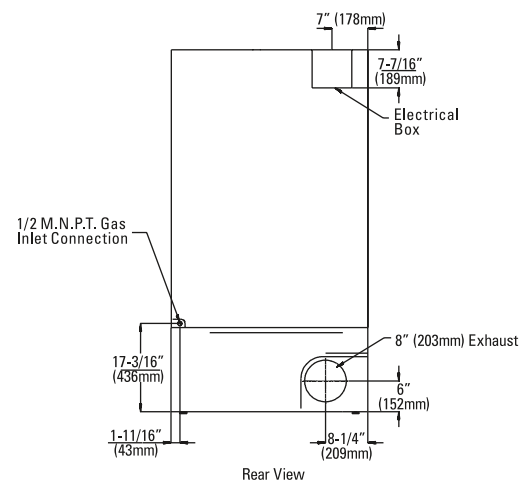

Rear View



MAYTAG® LIMITED WARRANTY 3 YEARS — ALL PARTS

For a period from the date of original purchase through the time listed above, the designated parts that fail in normal commercial use will be repaired or replaced free of charge for the part itself, with the owner paying all other costs, including labor, transportation and customs duty. Chemical damage is excluded from all warranty coverage. See complete warranty for details.